

DESCRIPTION

- The GPS/DCF antenna enables the synchronisation of products lacking a GPS input but which are equipped with a DCF input.
- The GPS/DCF antenna receives the time signal from GPS satellites and converts it into a DCF signal. This antenna simulates the signal received from a radio antenna situated in Europe.
- The transmitted time is the local time, the time zone being programmed in the antenna at the factory (the location where the antenna will be installed must be specified at ordering time).



See product page on
>> www.bodet-time.com <<



STANDARDS

- Low voltage directive: EN 60950.
- EMC Directive:
 - EN 61000-6-1: Immunity for Residential, commercial and light-industrial environments.
 - EN 61000-6-3: Emissions for Residential commercial and light-industrial environments.

GENERAL FEATURES

- **Receiver**..... 12 channels receiver L1 = 1 575 MHz.
- **Power supply**..... 8-20 VDC 4/20 mA current loop.
- **Transmitted data**..... DCF 4/20 mA current loop.
- **Outdoor installation**..... Horizontally on a roof or a pole.
Possible installation behind a glass pane or under a plastic cover.
- **Connection**..... 1 cable.
- **Cable**..... 2-wire (0.25mm²) cable. A 20 m cable is supplied with the antenna.
- **Construction**..... Grey (RAL9002) ABS casing with integrated swivel bracket (for orientation toward the sky), mounting with 1 x Ø 4 mm screw.
- **Operating temperature range**..... -30°C to +70°C.
- **Storage temperature range**..... -40°C to +85°C.
- **Protection index**..... IP67 – IK04.

OPERATION

- A blue LED (visible from below) indicates how the antenna is operating.
- LED OFF = the antenna is not powered.
- LED ON steady = the antenna is searching for the GPS sync.
- LED Blinking at the rate of 1 sec. = the antenna is GPS synchronised and transmitting the time information in DCF format (The antenna transmits during 5 minutes (LED blinking) then the antenna search for another GPS synchronisation (LED ON steady during few seconds)).

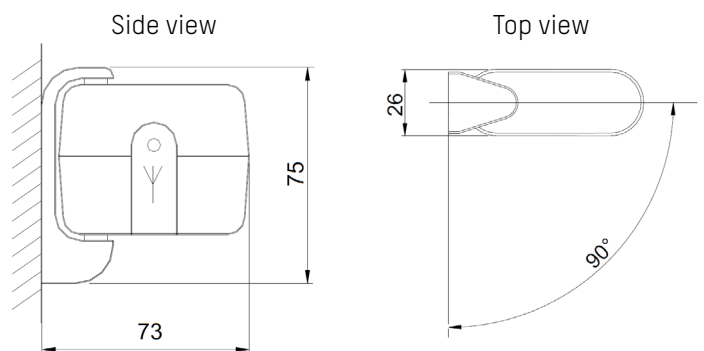
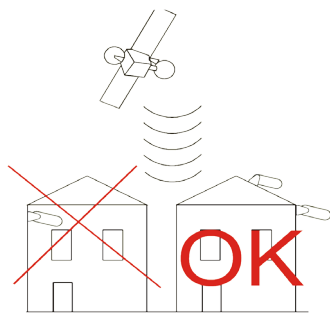

Dimensions in mm

REFERENCE

- **907 038**..... GPS-DCF antenna
Warning: when ordering, specify the country where the product will be installed.

